



**BAINES
MASONRY**
Quality First

StoneFace™ *A new concept in architectural masonry*

**Innovative Feature
Wall System Suitable
for:**

- ✓ Feature Walls
- ✓ Retaining Walls
- ✓ Fences
- ✓ Thin Bed Mortar System
- ✓ Structural and
Non-Structural

Veneer

- ✓ Cladding



Australian Owned, Designed and Manufactured

member of



BAINES MASONRY
900 Wilton Road (P.O. Box 89) Appin NSW 2560
Tel: (02) 4631 1383 Fax: (02) 4631 1402
info@bainesmasonry.com.au
www@bainesmasonry.com.au

Product Information: Stoneface™ Blocks

FULL BLOCK

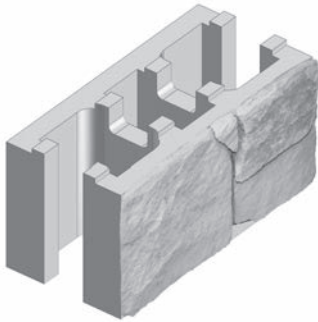

HALF BLOCK

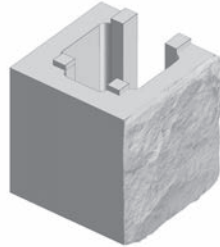

FULL CORNER

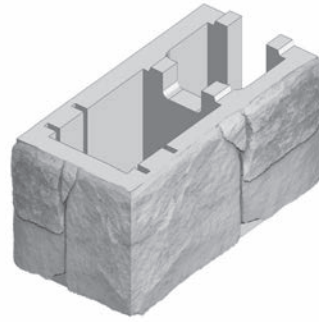

HALF CORNER

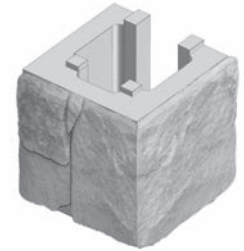

SRW Adhesive

Build your walls with SRW Adhesive instead of mortar and you'll save **TIME & MONEY.**

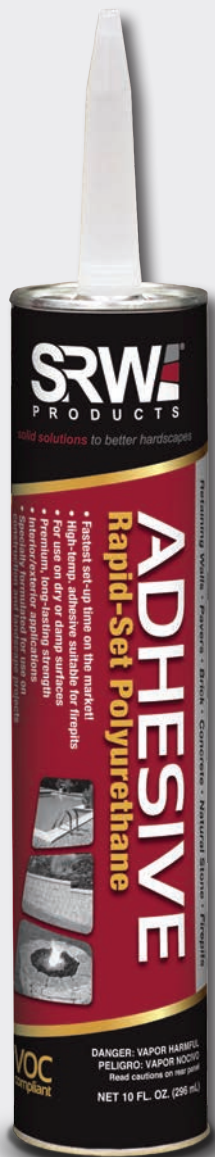

WHY ?

- ✓ Fastest set-up time on the market!
- ✓ High temperature adhesive suitable for firepits
- ✓ For use on dry or damp surfaces
- ✓ Premium, long lasting strength
- ✓ Interior/exterior use
- ✓ Specially formulated for use on construction and landscape projects

SRW Adhesive is a rapid-set polyurethane adhesive formulated to permanently bond concrete masonry block structures.

Segmental Retaining Walls



Segmental Retaining Walls— It's Our Business!

Baines Masonry specialises in retaining wall products that are built to last. From SRW Adhesive and geotextiles to sealers and preliminary designs, you can count on our time-tested products, as well as our new, innovative solutions. After all, we are SRW Products.



Veneer



StoneFace™ Veneer

StoneFace™ is also available as a veneer face stone which can be fixed to an existing structure. It is available in the same colours as the StoneFace™ block. We recommend using SRW's Vertical Instant Lock for fixing the StoneFace™ Veneer

Stoneface™ Finish

StoneFace™ is a new concept in architectural masonry developed by Baines Masonry.

At Baines Masonry, we have developed a system of attaching a stone face finish on a masonry block during the manufacturing process.

This is a reconstituted stone finish inspired by our unique Australian landscape, both rugged and stunning, and comes in four finishes.



BushRock Blend



Charcoal Blend



YellowRock Blend



OpalRock Blend

StoneFace™ Block

The StoneFace™ block lends itself to a variety of uses:

- ✓ Retaining Walls
 - Steel and concrete reinforced cantilever
 - Segmental, using the EarthWorks™ retainers
- ✓ Feature Walls
- ✓ Entry Ways
- ✓ Fences
- ✓ Commercial and Domestic construction

The block system is fixed using SRW thin bed masonry adhesive and cement mortar achieving the look of a dry stacked stone wall built by stonemasons in early Australia.

When constructing a segmental retaining wall the EarthWorks™ retainers enable a dry stacked retaining wall to be built. The use of the SRW adhesive is only required for the capping units.



StoneFace™ Veneer

As well as the Block system, StoneFace™ is also available as a veneer face stone which can be fixed to an existing structure. It is available in the same colours as the StoneFace™ block. We recommend using SRW's Vertical Instant Lock for fixing the StoneFace™ Veneer

